



Scanning Stage SCAN^{plus} 100 × 100 for Upright Microscopes

Specifications

Travel range	max. 100 × 100 mm
Ball screw pitch	4 mm
Travel speed	max. 240 mm/s
Repeatability	≤ 0.2 µm ¹
Accuracy	±1 µm ²
Resolution	0.05 µm (smallest step size)
Orthogonality	< 10 arcsec
Motor type	2-phase stepper motor
Limit switches	continuously adjustable optical light barriers
Material / surface	aluminium / anodic coating, black lacquered
Weight	approx. 4.6 kg

Order Information

Order No.: 00-24-575-0000

Product Features

- ▶ integrated linear measuring systems for highest accuracy
- ▶ flat, ergonomic design with rounded corners
- ▶ plain surface for easy cleaning
- ▶ exchangeable stage inserts for different kinds of applications
- ▶ continuously adjustable optical light barriers for individual travel range limitation
- ▶ integrated electronic stage identification device ETS for automatic identification of the scanning stage and parametrization of the controller
- ▶ **5 years guarantee**, if the scanning stage is operated in the system with the Märzhäuser TANGO controller

Dimensions

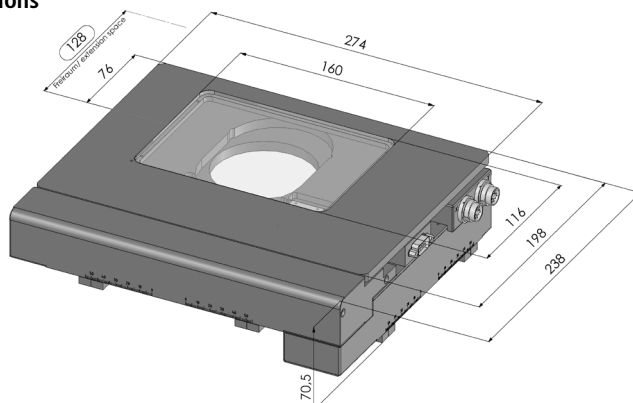

Accessories

Glass plate (included in delivery)

Order No.: 00-24-427-0810

For further accessories please visit:

www.marzhauser.com