

## Scanning Stage SCAN IM 120 × 80 for Olympus IX53 / IX73 / IX83

### Specifications

Travel range	max. 120 × 80 mm
Travel speed	max. 120 mm/s (with 2 mm ball screw pitch)
Repeatability	< 1 µm <sup>1</sup> (bidirectional)
Accuracy	±3 µm <sup>1</sup>
Resolution	0.01 µm (smallest step size)
Orthogonality	< 10 arcsec
Motor type	2-phase stepper motor
Limit switches	wear-free Hall sensors
Material / surface	aluminium / anodic coating, black lacquered
Weight	approx. 4.5 kg

### Dimensions

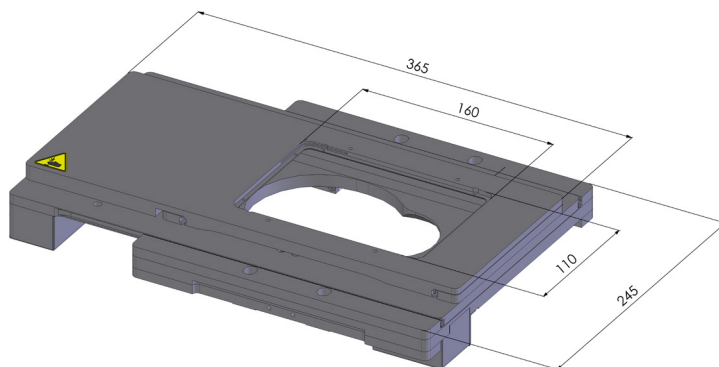

### Order Information

Order No.: 00-24-578-0000

### Product Features

- ▶ flat, ergonomic design with rounded corners
- ▶ plain surface for easy cleaning
- ▶ stationary connecting cables between scanning stage and controller
- ▶ integrated electronic stage identification device ETS for automatic identification of the scanning stage and parametrization of the controller
- ▶ **5 years guarantee**, if the scanning stage is operated in the system with the Märzhäuser TANGO controller

### Accessories

Stage insert for 1 slide 3" × 1"  
 (included in delivery)  
 Order No.: 00-29-411-8010

Piezo Z-stage 300 µm  
 Order No.: 00-55-550-0800

Piezo Z-stage 500 µm  
 Order No.: 00-55-600-0801

Various stage inserts  
 with dimensions 160 × 110 × 8 mm

For further accessories please visit:  
[www.marzhauser.com](http://www.marzhauser.com)