

## Scanning Stage SCAN IM 120 × 80 for Nikon Eclipse MA100 / MA100L

### Specifications

Travel range	120 × 80 mm
Travel speed	max. 60 mm/s (with 1 mm ball screw pitch) max. 120 mm/s (with 2 mm ball screw pitch)
Repeatability	< 1 µm <sup>1</sup> (bidirectional)
Accuracy	±3 µm <sup>1</sup>
Resolution	0.01 µm (smallest step size)
Orthogonality	< 10 arcsec
Motor type	2-phase stepper motor
Limit switches	wear-free Hall sensors
Material / surface	aluminium / anodic coating, black lacquered
Weight	approx. 4,7 kg

### Order Information

Order No.: 00-24-583-0000 (1 mm)  
 Order No.: 00-24-584-0000 (2 mm)

### Product Features

- ▶ flat, ergonomic design with rounded corners
- ▶ plain surface for easy cleaning
- ▶ stationary connecting cables between scanning stage and controller
- ▶ integrated electronic stage identification device ETS for automatic identification of the scanning stage and parameterization of the controller
- ▶ **5 years guarantee**, if the scanning stage is operated in the system with the Märzhäuser TANGO controller

### Dimensions

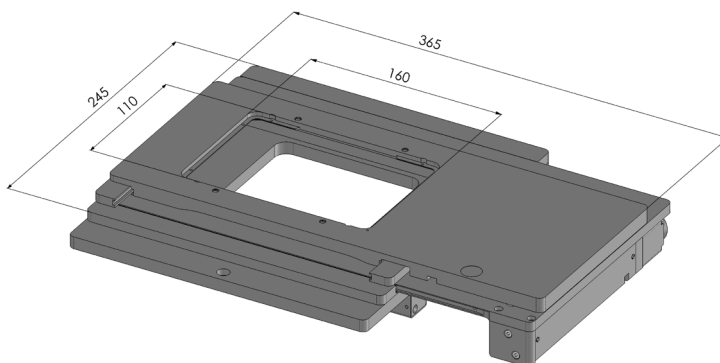

### Accessories

Stage insert for 1 slide 3" × 1"  
 (included in delivery)  
 Order No.: 00-29-411-8010

Piezo Z-stage  
 Order No.: 00-55-550-0800 (300 µm)  
 Order No.: 00-55-600-0801 (500 µm)

For further accessories please visit:  
[www.marzhauser.com](http://www.marzhauser.com)