



Scanning Stage SCAN^{plus} IM 120 × 80 for Olympus IX51 / IX71 / IX81

Specifications

Travel range	max. 120 × 80 mm
Travel speed	max. 60 mm/s (with 1 mm ball screw pitch) max. 120 mm/s (with 2 mm ball screw pitch)
Repeatability	< 1 µm ¹ (bidirectional)
Accuracy	±1 µm ¹
Resolution	0.05 µm (smallest step size)
Orthogonality	< 10 arcsec
Motor type	2-phase stepper motor
Limit switches	mechanical limit switches
Material / surface	aluminium / anodic coating, black lacquered
Weight	approx. 4.7 kg

Order Information

Order No.: 00-24-585-0000 (1 mm)
 Order No.: 00-24-586-0000 (2 mm)

Product Features

- ▶ integrated linear measuring systems for highest accuracy
- ▶ flat, ergonomic design with rounded corners
- ▶ plain surface for easy cleaning
- ▶ stationary connecting cables between scanning stage and controller
- ▶ compatible with Olympus ZDC and (F)RFACA
- ▶ integrated electronic stage identification device ETS for automatic identification of the scanning stage and parametrization of the controller
- ▶ **5 years guarantee**, if the scanning stage is operated in the system with the Märzhäuser TANGO controller

Dimensions

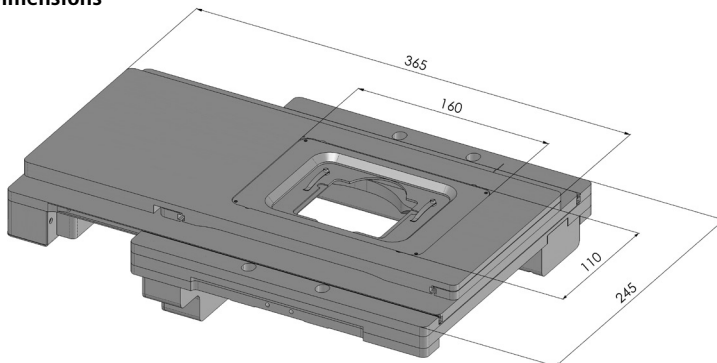

Accessories

Stage insert for 1 slide 3" × 1"
 (included in delivery)
 Order No.: 00-29-411-8010

Piezo Z-stage
 Order No.: 00-55-550-0800

Various stage inserts
 with dimensions 160 × 110 × 8 mm