

Scanning Stage SCAN^{plus} 75 × 50 with Integrated Measuring System

Specifications

Travel range	75 × 50 mm
Travel speed	max. 50 mm/s (with 2 mm lead screw pitch)
Repeatability	< 1 µm (bidirectional) ¹
Accuracy	±1 µm ¹
Resolution	0.05 µm (smallest step size)
Orthogonality	≤ 5 arcsec
Motor type	2-phase stepper motor
Limit switches	light barriers
Stage opening	160 × 116 mm
Material / surface	aluminium / anodic coating, black lacquered
Weight	approx. 2.6 kg (without stage insert)

Order Information

Order No.: 00-24-594-0000
 (2 mm lead screw pitch)

Product Features

- ▶ highest accuracy through integrated linear measuring systems
- ▶ flat, ergonomic design with rounded corners
- ▶ plain surface for easy cleaning
- ▶ exchangeable stage inserts for different kinds of applications
- ▶ motor/encoder cable connections front right
- ▶ integrated electronic stage identification device ETS for automatic identification of the scanning stage and parametrization of the controller
- ▶ **5 years guarantee**, if the scanning stage is operated in the system with the Märzhäuser TANGO controller

Dimensions

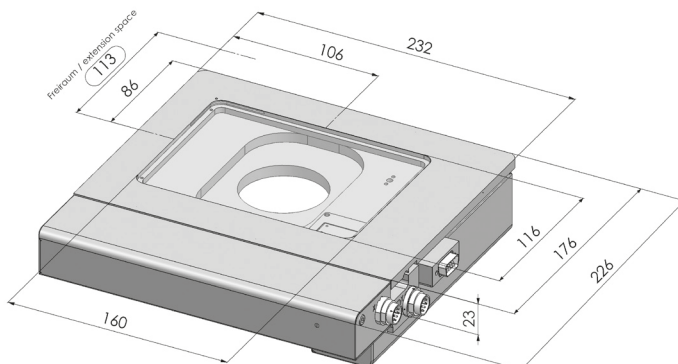

Accessories

Glass plate (included in delivery)
 Order No.: 00-24-427-0810

Stage insert for 1 slide 76 × 26 mm (3" × 1")
 Order No.: 00-24-427-8030

For more accessories please visit:
www.marzhauser.com