

## Scanning Stage SCAN IM 130 × 85 for Leica DMI3000 – DMI6000, DMi8

### Specifications

Travel range	max. 130 × 85 mm
Travel speed	max. 120 mm/s
Ball screw pitch	2 mm
Repeatability	< 1 µm <sup>1</sup> (bi-directional)
Accuracy	±3 µm <sup>1</sup>
Resolution	0.01 µm (smallest step size)
Orthogonality	< 10 arcsec
Motor	2-phase stepper motor
Limit switches	wear-free Hall sensors
Material / surface	aluminium / anodic coating, black lacquered
Weight	approx. 5 kg

### Order Information

Order No.: 00-24-598-0000

### Product Features

- ▶ flat, ergonomic design with rounded corners
- ▶ plain surface for easy cleaning
- ▶ stationary connecting cables between scanning stage and controller
- ▶ integrated electronic stage identification device ETS for automatic identification of the scanning stage and parametrization of the controller
- ▶ **5 years guarantee**, if the scanning stage is operated in the system with the Märzhäuser TANGO controller

### Dimensions

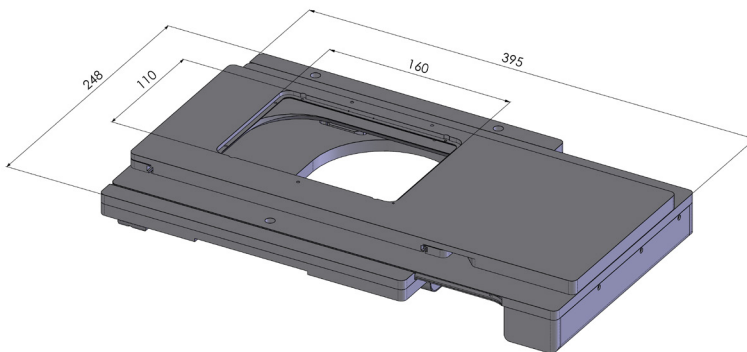

### Accessories

Piezo Z-stage  
 Order No.: 00-55-550-0800

For various stage inserts with dimensions 160 × 110 × 8 mm and further accessories please visit: [www.marzhauser.com](http://www.marzhauser.com)