

Scanning Stage SCAN IM 130 × 85 for Nikon Eclipse Ts2R

Specifications

Travel range	max. 130 × 85 mm
Travel speed	max. 120 mm/s (with 2 mm ball screw pitch)
Repeatability	< 1 µm ¹ (bidirectional)
Accuracy	±3 µm ¹
Resolution	0.01 µm (smallest step size)
Orthogonality	≤ 5 arcsec
Motor type	2-phase stepper motor
Limit switches	Hall sensors
Material / surface	aluminium / anodic coating, black lacquered
Weight	approx. 7.4 kg (without stage insert)

Order Information

Order No.: 00-24-639-0000

Product Features

- ▶ flat, ergonomic design enables easy loading of the scanning stage
- ▶ plain surface for easy cleaning
- ▶ stationary connecting cables between controller and scanning stage
- ▶ integrated electronic identification plate ETS for automatic identification of the scanning stage
- ▶ **5 years guarantee**, if the scanning stage is operated in the system with the Märzhäuser TANGO controller

Dimensions

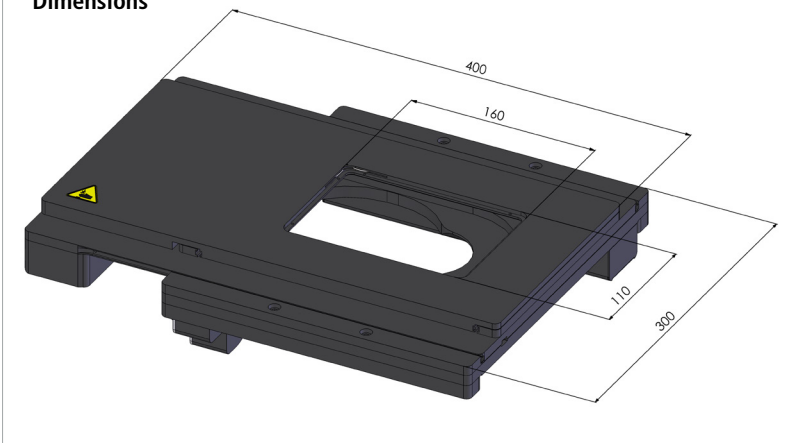

Accessories

Stage insert for 1 slide 76 × 26 mm
 (included in delivery)

Order No.: 00-29-411-8010

For more accessories please visit:
www.marzhauser.com