



Stage insert for 4 slides optionally available

Scanning Stage SCAN^{plus} 130 × 85 with Integrated Measuring System

Specifications

| | |
|--------------------|---|
| Travel range | max. 130 × 85 mm |
| Travel speed | max. 240 mm/s (with 4 mm ball screw pitch) |
| Repeatability | < 1 µm (bi-directional) ¹ |
| Accuracy | ±1 µm ¹ |
| Resolution | 0.05 µm (smallest step size) |
| Orthogonality | < 10 arcsec |
| Motor | 2-phase stepper motor |
| Limit switches | continuously adjustable optical light beams |
| Material / surface | aluminium / anodic coating, black lacquered |
| Weight | ca. 4.5 kg (without stage insert) |

Order Information

Order No.: 00-24-651-0000
 (4 mm ball screw pitch)

Product Features

- ▶ **highest accuracy** through integrated linear measuring system
- ▶ flat, ergonomic design enables **easy loading** of the scanning stage
- ▶ plain surface for **easy cleaning**
- ▶ **exchangeable stage inserts for different kinds of applications**, also for well plates or 4 slides
- ▶ continuously adjustable optical light beams for **individual travel range limitation**
- ▶ integrated electronic identification plate ETS for **automatic identification of the scanning stage**
- ▶ **5 years guarantee**, if the scanning stage is operated in the system with the Märzhäuser TANGO controller

Accessories

Glass plate (included in delivery)
 Order No.: 48-24-520-0810

Stage insert for 4 slides 76 × 26 mm (3" × 1")
 Order No.: 48-24-520-3000

For further accessories please visit:
www.marzhauser.com

Dimensions

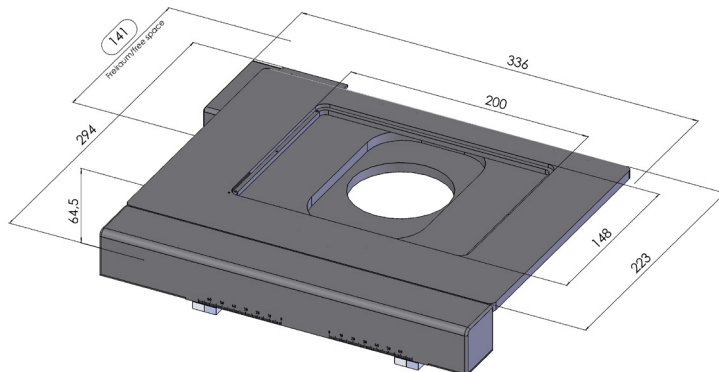

Width depending on the selected stage connection