

Scanning Stage SCAN^{plus} 200 × 200 for Upright Microscopes

Specifications

Travel range	max. 200 × 200 mm
Travel speed	max. 240 mm/s (with 4 mm ball screw pitch)
Repeatability	< 1 µm ¹ (bidirectional)
Accuracy	±1 µm ¹
Resolution	0.05 µm (smallest step size)
Orthogonality	< 10 arcsec
Motor type	2-phase stepper motor
Limit switches	Hall sensors
Material / surface	aluminium / anodic coating, black lacquered
Weight	approx. 8.9 kg

Order Information

Order No.: 00-24-832-0000

Product Features

- ▶ flat, ergonomic design with rounded corners
- ▶ integrated linear measuring systems for highest accuracy
- ▶ for reflected and transmitted light applications
- ▶ L-shaped support stages optional available
- ▶ integrated electronic stage identification device ETS for automatic identification of the scanning stage and parametrization of the controller
- ▶ **5 years guarantee**, if the scanning stage is operated in the system with the Märzhäuser TANGO controller

Dimensions

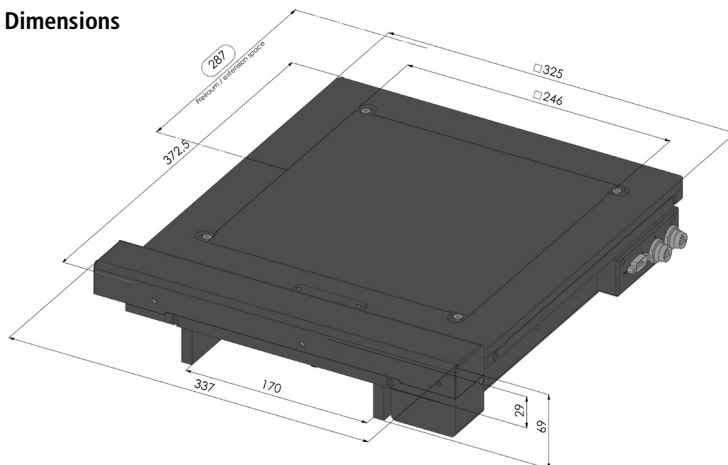

Accessories

Metall plate (included in delivery)
 Order No.: 00-24-801-0011

For more accessories please visit:
www.marzhauser.com