



ERGODRIVE Operating Device for Motorized Microscope and Measuring Stages

Specifications

Number of axes	ERGODRIVE 2: 2 axes (XY) ERGODRIVE 3: 3 axes (XYZ)
Resolution XY	100.000 steps/revolution
Resolution Z ¹	480 steps/revolution
Supply voltage	+5 V
Current consumption	70 mA
Interface	HD D-sub 15-pin plug
Material	aluminium
Surface	anodic coating, black lacquered
Weight	ERGODRIVE 2: approx. 1.5 kg ERGODRIVE 3: approx. 1.6 kg

Dimensions

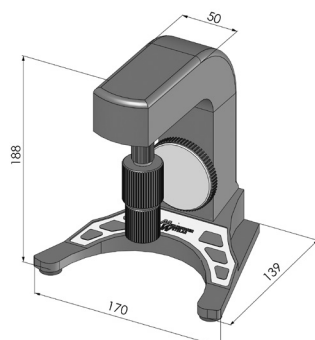

Fig. shows ERGODRIVE 3

Order Information

ERGODRIVE 2, 2-axes operating device
 Order No.: 00-27-322-1600

ERGODRIVE 3, 3-axes operating device
 Order No.: 00-27-322-1500

Product Features

- ▶ 2- or 3-axes operating device for all motorized microscope and measuring stages in connection with TANGO controller
- ▶ high-resolution, proportional positioning
- ▶ fast stage movement across the entire travel range with sensitive positioning in sub- μ area at the same time
- ▶ ergonomical adjustment for friction and height (coaxial drive telescopic)
- ▶ SnapShot function
- ▶ velocity switching for XY, respectively Z
- ▶ "Plug and play your microscope": automatic identification by connection

Accessories

Operating device ERGODRIVE is compatible with all TANGO controllers.