

▶ **Motorized Measuring Stage MT mot 200 x 100 MR** with Integrated Measuring System

<b>Measuring range:</b>	200 x 100 mm (8" x 4")
<b>Repeatability:</b>	< 1 µm
<b>Accuracy:</b>	+/- 1 µm
<b>Resolution:</b>	< 0,05 µm
<b>Motor:</b>	2-phase stepper motor
<b>Max. travel speed:</b>	60 mm/s (1 mm ball screw pitch) 120 mm/s (2 mm ball screw pitch)
<b>Limit switches:</b>	mechanical limit switches
<b>Weight:</b>	9,000 g
<b>Load capacity:</b>	5,000 g

**Order Information**

MT mot 200 x 100 MR,  
with 1 mm ball screw pitch  
Order No.: 00-34-106-0000

MT mot 200 x 100 MR,  
with 2 mm ball screw pitch  
Order No.: 00-34-107-0000

**Product Features**

- ▶ for measuring in reflected or transmitted light
- ▶ with integrated measuring system

**Dimensions:**

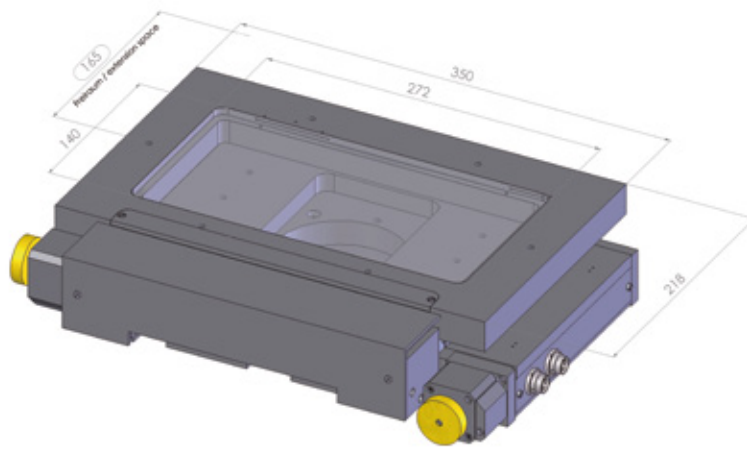

**Accessory**

Glass plate  
(included in delivery)  
Order No.: 00-31-101-0810

For further accessories please refer to:  
[www.marzhauser.com](http://www.marzhauser.com)