



Motorized Measuring Stage MT mot 200 × 100 for Hardness Tests

Specifications	
Travel range	max. 200 × 100 mm
Repeatability ¹	< 1 µm ¹ (unidirectional)
Accuracy	±3 µm ¹
Resolution	0.01 µm (smallest step size)
Orthogonality	< 10 arcsec
Motor	2-phase stepper motor
Travel speed	max. 60 mm/s
Limit switches	integrated Hall sensors
Material / surface	aluminium/anodic coating, black lacquered
Worktop	CERASIST® coated, free of wear
Weight	approx. 11.1 kg

Order Information

Order No.: 00-34-109-0000

Product Features

- ▶ hardness tests with proof load up to 3000 N
- ▶ flexible adaptation by T-slots
- ▶ CERASIST® surface, free of wear
- ▶ travel range limitation by integrated Hall sensors
- ▶ integrated electronic stage identification device ETS for automatic identification of the measuring stage and parametrization of the controller
- ▶ motor cable connection back right

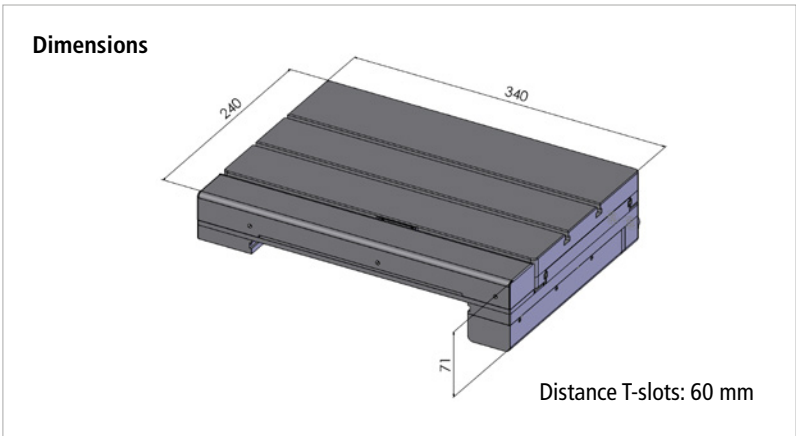

For more products please visit:
www.marzhauser.com