

Motorized Measuring Stage MT mot 100 × 100 MR with Integrated Measuring System

Specifications

Travel range	max. 100 × 100 mm
Travel speed	max. 60 mm/s (with 1 mm ball screw pitch) max. 120 mm/s (with 2 mm ball screw pitch)
Repeatability	< 1 µm (bi-directional) ¹
Accuracy	±1 µm ¹
Resolution	< 0.05 µm (smallest step size)
Motor	2-phase stepper motor
Material	aluminium
Surface	anodic coating, black laquered
Load capacity	5.0 kg
Weight	approx. 7.5 kg

Order Information

Order No.: 00-34-403-0000 (1 mm)
 Order No.: 00-34-404-0000 (2 mm)

Product Features

- ▶ for measuring in reflected or transmitted light
- ▶ highest accuracy through integrated linear measuring systems
- ▶ integrated electronic stage identification device ETS for automatic identification of the measuring stage and parametrization of the controller
- ▶ **5 years guarantee**, if the scanning stage is operated in the system with the Märzhäuser TANGO controller

Dimensions

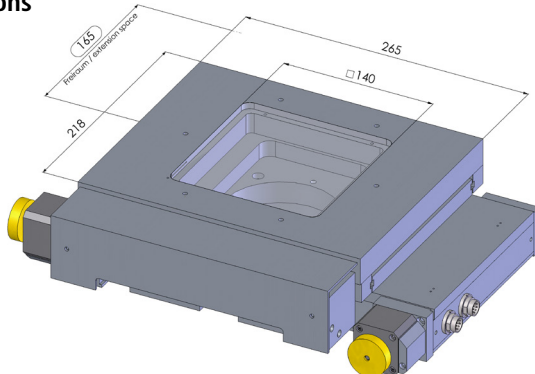

Accessories

Glass plate (included in delivery)
 Order No.: 00-34-401-0810

For further accessories please visit:
www.marzhauser.com