

Motorized Measuring Stage MT mot 50 × 50 for reflected light applications

Specifications	
Travel range	50 × 50 mm
Ball screw pitch	1 mm
Travel speed	max. 60 mm/s
Repeatability ¹	< 1 µm ¹ (bidirectional)
Accuracy	±1 µm ¹
Resolution	< 0,01 µm (smallest step size)
Motor type	2-phase stepper motor
Material	Aluminium
Surface	Anodic coating, black lacquered
Weight	approx. 4.6 kg
Load	10 kg

Order Information

MT mot 50 × 50
 Order No.: 00-36-104-0000

Product Features

▶ for reflected light applications

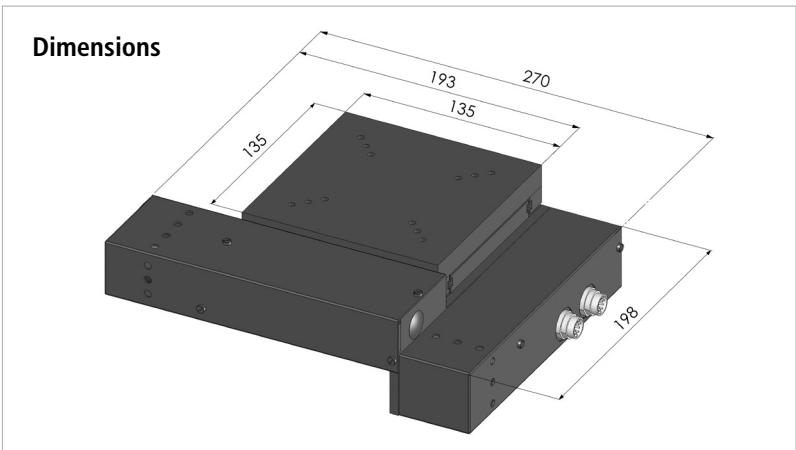

Dimensions

For more products please visit:

www.marzhauser.com



¹ measured according to VDI/DGQ 3441
 Specifications valid with TANGO controllers only.

Specifications are subject to change without notice.
 Issue: August 2023