

► **Motorized Measuring Stage MT mot 50 x 50** for hardness testing

Measuring range:	50 x 50 mm (2" x 2")
Repeatability:	< 1 µm
Accuracy:	absolut accuracy in µm: measuring length / 40 +2,5
Resolution:	< 0,01 µm
Motor:	2-phase stepper motor
Max. travel speed:	60 mm/s, with 1 mm ball screw pitch
Weight:	3,500 g
Load capacity:	5,000 g

Order Information

MT mot 50 x 50,
with 1 mm ball screw pitch
Order No.: 00-36-109-0000

Product Features

- for hardness testing
- flat design

Dimensions:

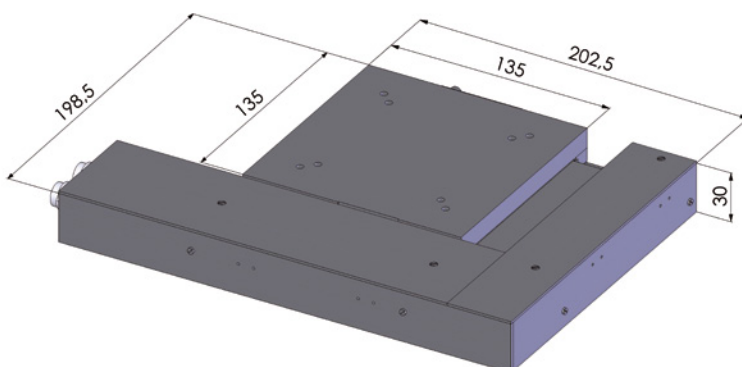

Accessory

For accessories please refer to:
www.marzhauser.com