

Stage insert/inlay not included in delivery

## Scanning Stage SCAN IM 100 × 45 for Leica DMI3000 – DMI6000, DMI8

### Specifications

Travel range	max. 100 × 45 mm
Travel speed	max. 120 mm/s (2 mm ball screw pitch)
Repeatability	< 1 µm <sup>1</sup> (bidirectional)
Accuracy	±3 µm <sup>1</sup>
Resolution	0.05 µm (smallest step size)
Orthogonality	≤ 5 arcsec
Motor type	2-phase stepper motor
Limit switches	wear-free Hall sensors
Material / surface	aluminium / anodic coating, black lacquered
Weight	approx. 5.1 kg

### Dimensions

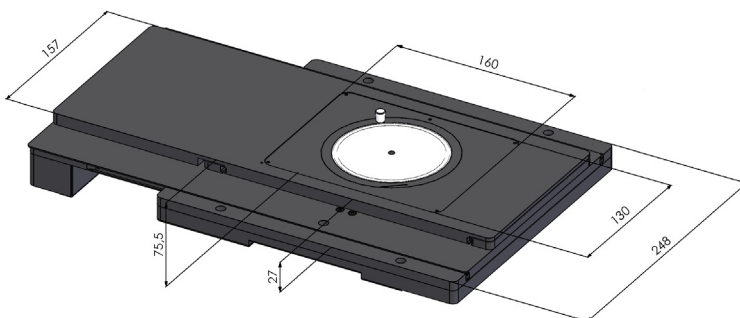

### Order Information

Order No.: 31-24-433-0000

### Product Features

- ▶ flat, ergonomic design with rounded corners
- ▶ plain surface for easy cleaning
- ▶ stationary connecting cables between scanning stage and controller
- ▶ **5 years guarantee**, if the scanning stage is operated in the system with the Märzhäuser TANGO controller

### Accessories

Stage insert for stage inlay 160 × 130 mm  
 Order No.: 31-27-344-0016

Stage inlay with opening  
 Ø 5 mm, Order No.: 31-27-344-2005  
 Ø 10 mm, Order No.: 31-27-344-2010  
 Ø 20 mm, Order No.: 31-27-344-2020  
 Ø 30 mm, Order No.: 31-27-344-2030  
 Ø 40 mm, Order No.: 31-27-344-2040

For accessories please visit:

[www.marzhauser.com](http://www.marzhauser.com)