

Motorized Microscope Stage S mot i 150 × 100 for Stereo Microscopes

Specifications	
Travel range	max. 150 × 100 mm
Travel speed	max. 50 mm/s
Repeatability	< 1 µm ¹ (bidirectional)
Accuracy	±3 µm ¹
Resolution	0.05 µm (smallest step size)
Orthogonality	< 10 arcsec
Motor type	2-phase stepper motor
Limit switches	wear-free Hall sensors
Material / surface	aluminium / anodic coating, CERASIST® lacquer
Load	5 kg
Weight	approx. 7.5 kg

Order Information

Order No.: 45-24-610-0000

Product Features

- ▶ for material applications
- ▶ suitable for samples weighing up to 5 kg
- ▶ integrated controller TANGO integrale
- ▶ flat, ergonomic design
- ▶ plain surface for easy cleaning
- ▶ CERASIST® surface, free of wear

Accessories

Glass plate 160 × 116 × 3 mm
 (included in delivery)
 Order No.: 00-24-427-0810

Metal plate 160 × 116 × 3 mm
 Order No.: 00-24-427-0011

2-axes joystick digital
 Order No.: 00-76-200-1820

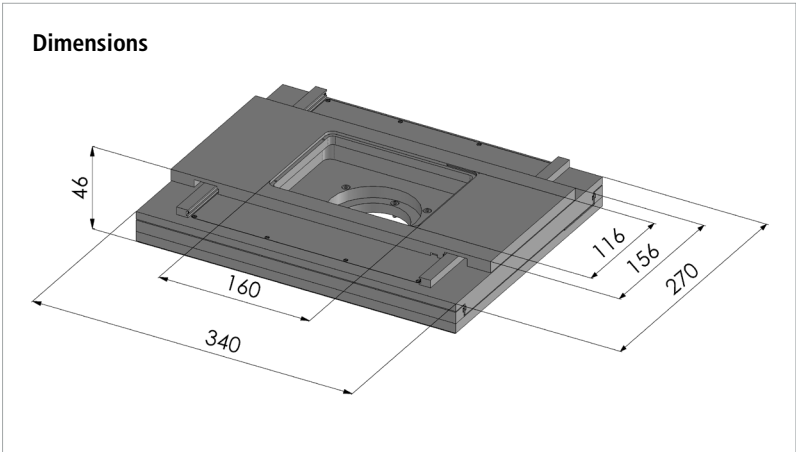

For more accessories please visit:
www.marzhauser.com



¹ measured according to VDI/DGQ 3441
 Specifications valid with TANGO controllers only.