



Scanning Stage SCAN^{plus} 200 × 200 for Nikon Eclipse L200/L200N/L200D/L200ND

Specifications

Travel range	max. 200 × 200 mm
Travel speed	max. 240 mm/s
Ball screw pitch	4 mm
Repeatability	< 1 µm ¹ (bidirectional)
Accuracy	±1 µm ¹
Resolution	0.05 µm (smallest step size)
Orthogonality	≤ 5 arcsec
Motor type	2-phase stepper motor
Limit switches	wear-free Hall sensors
Material / surface	aluminium / anodic coating, black lacquered
Weight	approx. 10 kg

Order Information

Order No.: 45-24-833-0000

Product Features

- ▶ flat, ergonomic design with rounded corners
- ▶ integrated linear measuring systems for highest accuracy
- ▶ for reflected and transmitted light applications
- ▶ integrated electronic stage identification device ETS for automatic identification of the scanning stage and parametrization of the controller
- ▶ **5 years guarantee**, if the scanning stage is operated in the system with the Märzhäuser TANGO controller

Dimensions

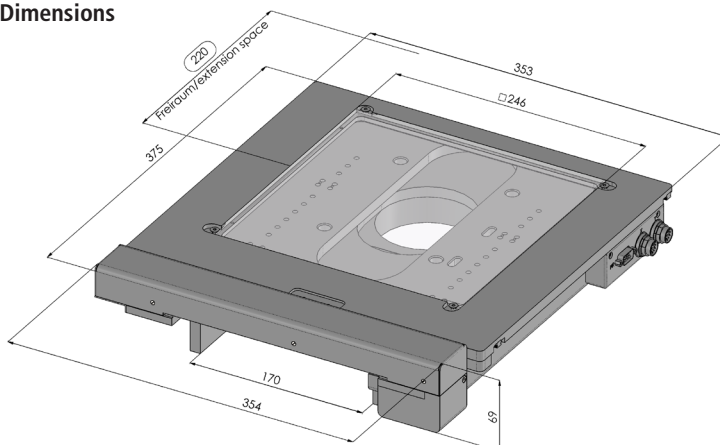

Accessories

Glass plate (included in delivery)

Order No.: 00-24-801-0810

Metall plate

Order No.: 00-24-801-0011

For more products please visit:

www.marzhauser.com