

Scanning Stage SCAN IM 112 × 74 for Olympus GX51/GX71

Specifications

Travel range	112 × 74 mm
Max. travel speed	max. 60 mm/s (with 1 mm ball screw pitch)
Repeatability	< 1 µm ¹ (bi-directional)
Accuracy	±3 µm ¹
Resolution	0.01 µm (smallest step size)
Orthogonality	< 10 arcsec
Motor type	2-phase stepper motor
Limit switches	mechanical limit switches
Material	aluminium
Surface	anodic coating, black lacquered
Weight	approx. 4.3 kg

Order Information

Order No.: 48-24-555-0000

Product Features

- ▶ exchangeable stage inserts for different kinds of applications
- ▶ integrated electronic stage identification device ETS for automatic identification of the scanning stage and parametrization of the controller
- ▶ **5 years guarantee**, if the scanning stage is operated in the system with the Märzhäuser TANGO controller

Accessories

Stage insert for 3 samples, Ø 41 mm
 (included in delivery)
 Order No.: 48-24-555-1000

Dimensions

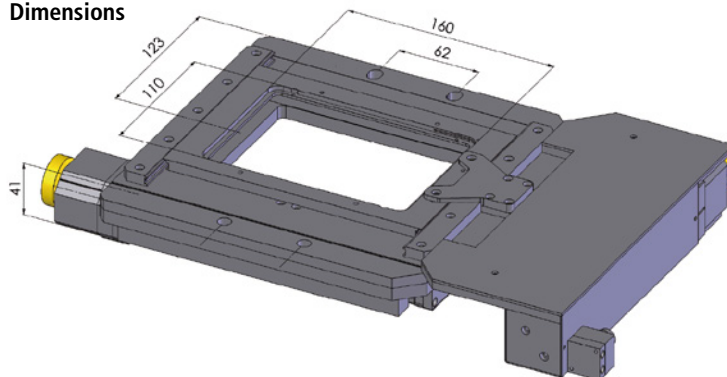

For more products please visit:

www.marzhauser.com