



▶ **Scanning Stage SCAN<sup>plus</sup> 130 x 85** for Olympus BX Series

<b>Travel range:</b>	130 x 85 mm
<b>Repeatability:</b>	< 1 µm (bi-directional, measured according to VDI / DGQ 3441)
<b>Accuracy:</b>	+/- 1 µm (measured according to VDI / DGQ 3441)
<b>Resolution:</b>	0,05 µm (smallest step size)
<b>Orthogonality:</b>	< 10 arc sec
<b>Motor:</b>	2-phase stepper motor
<b>Max. travel speed:</b>	240 mm/s, with 4 mm ball screw pitch
<b>Limit switches:</b>	continuously adjustable optical light beam
<b>Material:</b>	aluminium
<b>Surface:</b>	anodic coating, black lacquered
<b>Weight:</b>	4,400 g
<b>WEEE classification:</b>	product group 9
<b>WEEE weight:</b>	220 g

**Order Information**

Order No.: 48-24-651-0000, 4 mm ball screw pitch

**Product Features**

- ▶ with integrated MR measuring system
- ▶ exchangeable stage inserts for different kinds of applications, also for micro titer plates or 4 slides, on request
- ▶ user-friendly design due to lowered motor axis
- ▶ **5 years guarantee**, if the scanning stage is operated in the system with the Märzhäuser TANGO controller!
- ▶ continuously adjustable optical light beam for individual travel range limitation

**Dimensions:**

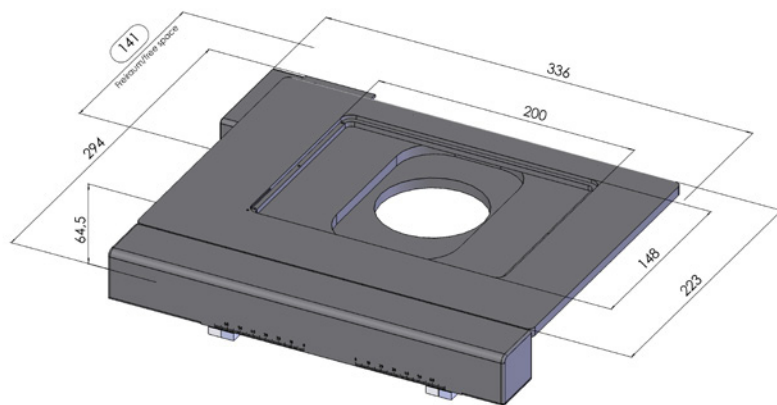

**Accessories**

- Stage insert for 4 slides  
(as shown in the image above, not included in scope of delivery)  
Order No.: 48-24-520-3000
- Stage insert for 1 or 2 slides  
(not included in scope of delivery)  
Order No.: 48-24-520-2000