

Scanning Stage SCAN IM 120 × 80 for Olympus IX85

Specifications	
Travel range	max. 120 × 80 mm
Travel speed	max. 120 mm/s (with 2 mm ball screw pitch)
Repeatability	< 1 µm ¹ (bidirectional)
Accuracy	±3 µm ¹
Resolution	0.01 µm (smallest step size)
Orthogonality	< 10 arcsec
Motor type	2-phase stepper motor
Limit switches	wear-free Hall sensors
Material	aluminium
Surface	anodic coating, black lacquered
Weight	approx. 6.8 kg

Order Information

Order No.: 48-4024-0502-0000

Product Features

- ▶ flat, ergonomic design with rounded corners
- ▶ plain surface for easy cleaning
- ▶ integrated stationary connecting cables between scanning stage and controller, cable length: 2 m
- ▶ integrated electronic stage identification device ETS for automatic identification of the scanning stage and parametrization of the controller
- ▶ **5 years guarantee**, if the scanning stage is operated in the system with the Märzhäuser TANGO controller

Accessories

Various Piezo Z-stages with travel ranges up to 500 µm

Various stage inserts with dimensions 160 × 110 × 8 mm

For more products please visit: www.marzhauser.com

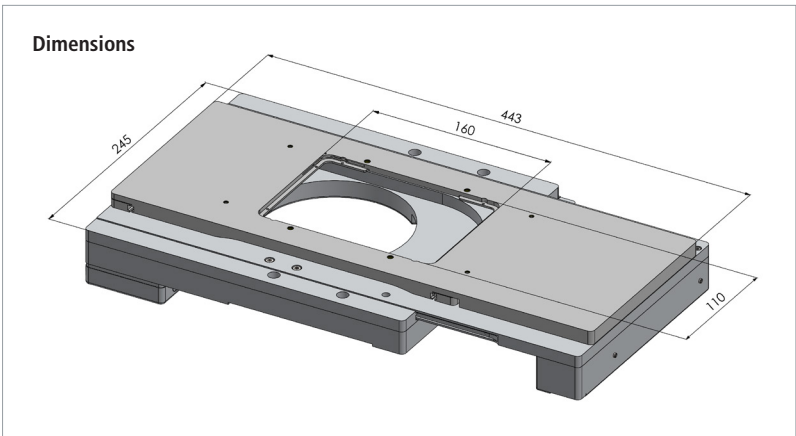

¹ measured according to VDI/DGQ 3441
 Specifications valid with TANGO controllers only.